

SUJATA®



SANDWICH MAKER | SW02

OPERATING MANUAL



READ THE INSTRUCTIONS CAREFULLY
BEFORE OPERATING THIS SANDWICH MAKER

READ ALL INSTRUCTIONS BEFORE USE.

WARNING

To reduce the risk of fire, electric shock, or serious personal injury:

- This appliance is not intended for use by persons (including children) with reduced physical, sensory or mental capabilities, or lack of experience and knowledge, unless they have been given supervision or instruction concerning use of the appliance by a person responsible for their safety.
- Children should be supervised to ensure that they do not play with the appliance.
- Always use the appliance on a flat, stable, heat-resistant surface.
- The temperature of the accessible surfaces may be very high when the appliance is in use. Make sure not to touch these hot parts of the appliance.
- Use the appliance in a well-ventilated area. Keep enough space on all sides of the appliance to allow adequate air circulation.
- Do not place the appliance on or near a gas or electric burner, or on top of a heated oven or other heat source.
- Do not allow the appliance to touch curtains, wall coverings, clothing, dishtowels, or other flammable materials during its use.
- Do not touch hot surfaces of the appliance. Do not move the appliance while it is plugged in. Allow the appliance to thoroughly cool before handling it.
- Do not use attachments, not recommended for use with this appliance or sold by the manufacturer.
- Do not use the appliance near water or other liquids.
- Do not place or drop the appliance into water or other liquids. If the appliance falls into water, immediately unplug it from the electrical outlet.
- Do not leave the appliance unattended while it is in use. The appliance is not intended to be operated by means of an external timer or separate remote-control system.
- Do not put any stress on the Power Cord where it connects to the appliance as the Power Cord could fray and break.
- Do not plug or unplug the appliance into/from an electrical outlet with a wet hand.
- Keep the appliance and its Power Cord away from heated surfaces.
- Never operate this appliance if it has a damaged Power Cord or Plug, is not working properly, has been dropped, damaged, or exposed to water or other liquids.

- If the power cord is damaged, it must be replaced by the manufacturer or its service agent or a similarly qualified person in order to avoid a hazard

CAUTION

To reduce the risk of personal injury or appliance/property damage:

- This appliance is intended for indoor, non-industrial, non-commercial, household use only as a sandwich/panini maker and healthy grill. Do not use the appliance outdoors or for any other purpose.
- Do not allow the Power Cord to hang where it may be tripped over or pulled (e.g., over the edge of a table or counter).

SPECIAL INSTRUCTIONS:

- To avoid a circuit overload when using this appliance, do not operate another high-wattage appliance on the same electrical circuit.
- A short power supply cord is provided with this appliance. An extension cord is not recommended for use with this appliance, but if one must be used:
 - The marked electrical rating of the cord must be at least as great as that of the appliance.
 - Arrange the extension cord so that it does not hang where it can be tripped over or pulled unintentionally.

IDENTIFICATION OF PARTS

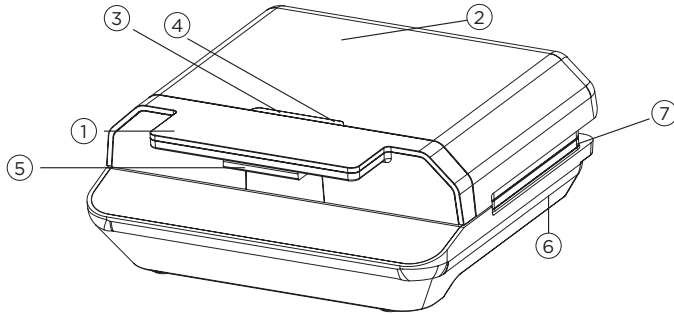

1. Handle
2. Upper Housing
3. Power Light (Red)
4. Ready Light (Green)
5. Handle Lock
6. Bottom Housing
7. Non-stick Plate

INSTRUCTIONS FOR USE

CAUTION: Do not use this appliance to cook or defrost frozen food. All food must be completely defrosted before cooking it with this appliance.

NOTE: During the initial uses of this appliance, it may produce some smoke. This is normal and will subside with further use.

1. Before using this appliance for the first time, clean it as described in the "Cleaning and Maintenance" section.
2. Press in the end of the Locking Latch nearest to the Handle to unlock the appliance.
3. Open the unit by pulling the Handle up.

4. Close the Plates and turn the unit on by plugging it into a standard electrical outlet. Verify that the Power Indicator Light illuminates in red.

WARNING: The Cooking Plates and metal surfaces of the unit will become extremely hot when in use. To avoid a burn hazard, wear heat resistant mitts or gloves and touch only the black portion of the Handle.

5. After the appliance preheats for approximately five minutes, the Ready Indicator Light will illuminate in green, indicating the appliance is ready for use.
6. Use the Handle to lift the Upper Plate. Place food on the Lower Plate using wooden or plastic heat-resistant utensils.
CAUTION: Do not use metal utensils on this appliance, as they will scratch and damage the Plates' non-stick coating.
7. Use the Handle to lower and rest the Upper Plate on top of the food.

NOTES:

- *The cooking time for different food depends on the type and thickness of the food.*
 - *Foods should be cooked thoroughly before consumption.*
8. When the food is cooked as desired, lift the Handle to open the Plates, then remove the food using the utensils. If more cooking will be done at this time, close the Plates to conserve heat.
 9. Repeat Steps 7-9 until cooking is complete, reapply cooking oil as necessary.
 10. Turn off the appliance by unplugging the Power Cord from the electrical outlet.
 11. When the appliance has completely cooled, clean and dry it.
 12. Lock the appliance in its closed position by pressing in the end of the Locking Latch farthest from the Handle.

CLEANING AND MAINTENANCE

- Before cleaning, unplug and wait for the appliance and the plates to cool down.
- Wipe the outside with only a slightly moistened cloth ensuring that no moisture, oil or grease enters the cooling slots.
- Do not clean the inside or outside with any abrasive scouring pad or steel wool as this will damage the finish.
- Do not immerse in water or any other liquid.

SPECIFICATIONS

Model Type & No.	SANDWICH MAKER (SW 02)
Power Supply	220-240V ~ 50-60 Hz
Power Consumption	750 W
Plate Type	Grill Plate
Material	Aluminium Plate with Teflon Coating



**WARRANTY IS NOT VALID IF
THIS PRODUCT IS USED FOR
COMMERCIAL PURPOSE**

SUJATA SANDWICH MAKER is warranted against manufacturing defects for a period of **TWO YEARS** from the date of purchase. Within this period any defective unit will be repaired or replaced at manufacturer's option, free of cost, subject to the unit being delivered to our authorised service centre at customer's cost. The warranty does not cover damages resulting from commercial use, accident, mishandling or negligence on the part of customer or non compliance of instructions in the operating manual or if the mechanism is tampered with by the customer or any unauthorised person other than our service personnel. The warranty card duly stamped and signed by the dealer alongwith the cash memo should be produced at the authorised service centre, otherwise the warranty will be treated as invalid. Liability for consequential damages or loss is neither accepted nor implied under the warranty.

All the images on the box and manual are for illustration purposes only, specifications are subject to change without notice.



Scan to visit
www.sujataappliances.com