

SUJATA®



SANDWICH MAKER | SW12

OPERATING MANUAL



READ THE INSTRUCTIONS CAREFULLY
BEFORE OPERATING THIS SANDWICH MAKER

IMPORTANT SAFEGUARDS

READ ALL INSTRUCTIONS

- Make sure the voltage in your outlet is the same as the voltage indicated on the appliance's rating label.
- Always turn the power off at the power outlet before you insert or remove a plug. Remove by grasping the plug – do not pull on the cord.
- Turn the power off and remove the plug when the appliance is not in use and before cleaning.
- Do not use your appliance with an extension cord unless this cord has been checked and tested by a qualified technician or service person.
- Close supervision is necessary when your appliance is being used by children or infirm persons.
- Young children should be supervised to ensure that they do not play with the appliance.
- Never leave the appliance unattended while in use.
- Do not use the appliance for any purpose other than its intended use.
- Do not place the appliance on or near a hot gas flame, electric element or any other appliance.
- Do not let the power cord of the appliance hang over the edge of a table or bench top or touch any hot surfaces.
- Do not operate the appliance if it has malfunctioned or has been damaged in any manner. In order to avoid the risk of an electric shock, never try to repair the appliance yourself. Take it to an authorized service center for examination and repair.
- Do not use outdoors or for commercial purposes.
- Unplug the unit when finished using.
- Do not immerse the appliance in water or any other liquid.

BEFORE THE FIRST USE

Remove all packaging materials.

Clean the cooking plates with a damp cloth or sponge.

Slightly grease the cooking plates with a little cooking oil.

Take care to prevent water from running into the appliance.

PARTS IDENTIFICATION

Before using your appliance for the first time, you should become familiar with all of the parts. Read all Instructions and Safeguards carefully.

1. Handle
2. Upper Housing
3. Power Light (Red)
4. Ready Light (Green)
5. Handle Lock
6. Bottom Housing
7. Non-stick Plate

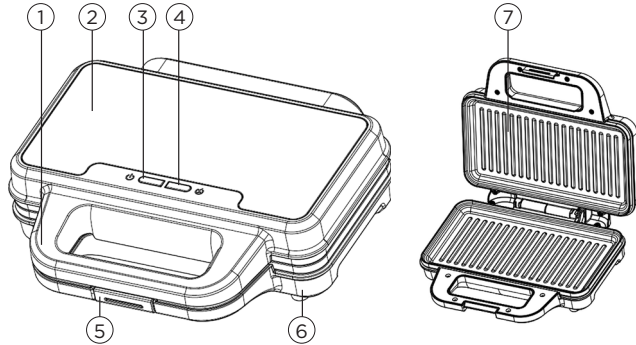

HOW TO USE

- Close the Sandwich Maker and plug it into the wall outlet, you will notice that the power light will glow, indicating that the Sandwich Maker has begun preheating.
- It will take approximately 3-5 minutes to reach cooking temperature, the ready light will glow.
- Open the lid, put the meat or other food on the bottom cooking plate.
- Close the lid. The ready light will go off again.
- Cook for about 3 to 5 minutes, the ready light goes on again, or until golden brown, adjusting the time to suit your own individual taste.

- When the food is cooked, use the handle to open the lid. Remove the food with the help of a spatula. Never use metal tongs or a knife as these can cause damage to the non-stick coating of the cooking plates.
- Once you are finished cooking, disconnect the plug from the wall outlet and leave unit open to cool.

CLEANING AND CARE

- Always turn off the power and remove the plug before cleaning.
- The cooking plates are coated with non-stick cooking surface, therefore little cleaning is required. Simply wipe cooking plates over with a damp cloth.
- Do not immerse the appliance in water or other liquids.
- Do not use abrasive scouring pads, powders or steel wool, cleaners.
- Do not place in the dishwasher.
- Before next use, lightly grease the cooking plates for easy removal of cooked food.

STORAGE

- Always unplug the appliance before storage.
- Always make sure the appliance is cool and dry before storing.
- To minimize storage space in your kitchen, the appliance can be stored vertically.

SPECIFICATIONS

Model Type & No.	SANDWICH MAKER (SW12)
Power Supply	220-240V - 50-60 Hz
Power Consumption	900 W
Plate	Grill Plate
Material	Aluminium Plate with Teflon Coating



WARRANTY IS NOT VALID IF THIS PRODUCT IS USED FOR COMMERCIAL PURPOSE

SUJATA SANDWICH MAKER is warranted against manufacturing defects for a period of **TWO YEARS** from the date of purchase. Within this period, any defective unit will be repaired or replaced at manufacturer's option, free of cost, subject to the unit being delivered to our authorised service centre at customer's cost. The warranty does not cover damages resulting from commercial use, accident, mishandling or negligence on the part of customer or non compliance of instructions in the operating manual or if the mechanism is tampered with by the customer or any unauthorised person other than our service personnel. The warranty card duly stamped and signed by the dealer alongwith the cash memo should be produced at the authorised service centre, otherwise the warranty will be treated as invalid. Liability for consequential damages or loss is neither accepted nor implied under the warranty.

All the images on the box and manual are for illustration purposes only, specifications are subject to change without notice.



Scan to visit
www.sujataappliances.com